



* Photo is for reference only.
Actual configuration will vary depending on application.

0V
input operating
voltage model
PLZ70UA

Modular Multifunction Electronic Load PLZ-U SERIES

Two load models (75 W/150 W) and two frame models (3 ch/5 ch)
High-speed response supporting a maximum slew rate of 2.4 A/ μ s (PLZ150U)
Minimum setting resolution of 10 μ A (PLZ70UA) or 20 μ A (PLZ150U)
0-V input operating voltage model (PLZ70UA)

Up to five load modules (same model) can be operated in parallel.

Frame control allows your system to be expanded to a multi-channel system configuration supporting up to 25 channels.
Timer functions combined with time/voltage measurement functions enable battery discharge characteristic evaluations.
The system features sequence and switching functions and is provided with GPIB and RS-232C ports as standard.

Designed to meet the needs of lower-voltage, higher-speed, and multi-channel testing applications

Modular Electronic Load!



0V
input operating
voltage model
PLZ70UA

Modular Multifunction Electronic Load

PLZ-U SERIES

For Testing Switching Power Supplies, Batteries, DC/DC Converters and Fuel Cells!

The current trend in semiconductors is towards lower voltages and higher speeds. This trend places similar demands on both the components of semiconductor power units, such as switching power supplies, batteries and DC/DC converters, and also on the electronic loads used for testing. Also, a growing number of users with a need for multiple-output power units and easy channel reconfiguration are calling for plug-in type electronic loads that can be easily configured to support multiple channels. The advent of an electronic load system that satisfies all these needs has been long awaited. It was against this background that we developed the PLZ-U Series of electronic loads.

The PLZ-U Series of compact and

high-performance modular electronic loads is capable of operating in five modes: constant current, constant resistance, constant voltage, constant current + constant voltage, and constant resistance + constant voltage. The load system consists of load modules and a frame. The load modules are inserted into the frame that also serves as a control unit. The PLZ-30F frame can accommodate up to three load modules, while the PLZ-50F frame can accommodate up to five. The load modules can be operated in parallel, so that the current capacity or power capacity can be changed easily, from 75 to 750 watts*¹, as needed for the device under test. In addition to offering high-speed response at a maximum slew rate of 2.4 A/ μ s*² and a minimum setting

resolution of 10 μ A*³, the system features a variety of functions including soft start, variable slew rate, a switching function, ABC preset memory function, four setup memories, and a sequence function. What's more, timer functions combined with time/voltage measurement functions allow you to measure battery discharge characteristics.

For communication, the system is provided with GPIB and RS-232C interfaces as standard. Both interfaces support IEEE 488.2 as well as the Standard Commands for Programmable Instruments (SCPI) commands, developed for testing and measuring instruments.

*¹ When five PLZ150U units are installed in a PLZ-50F frame

*² For the PLZ150U

*³ For the PLZ70UA

Features

Compact, lightweight body

The electronic load system is as wide as a 19-inch rack with a height of 3U. Weighing about 11 kg when configured for three channels or about 17 kg when configured for five channels, the system is compact, lightweight and space-saving.

High-speed response

In constant current mode, the electronic load is capable of offering high-speed response at a slew rate of 2.4 A/ μ s at the rising and falling edges of the current (equivalent to about 10 μ s when converted to the rise and fall times; in the case of PLZ150U). This allows transient response tests for direct current power supplies and simulations using dummy loads to be conducted under highly realistic load conditions.

High precision and high resolution

The built-in three-range configuration provides both wide dynamic range and high precision. The voltmeter, ammeter and wattmeter functions that display values using up to five digits each and a minimum setting resolution of either 10 μ A (PLZ70UA) or 20 μ A (PLZ150U) are implemented.

Variable slew rate

In constant current or constant resistance mode, the slew rate can be changed continuously. This helps suppress transient voltage drops due to wiring inductance, as well as transients in the constant voltage power supply and others, at the time of switching operation.

0-V input

The PLZ70UA model operates even when the input operating voltage is 0 V. This feature is indispensable for testing single-cell fuel cells. The continuing trend toward lower power consumption and semiconductor process miniaturization is driving semiconductor devices to operate with increasingly lower voltages. This makes PLZ70UA suitable for use when evaluating such power supplies.

Multi-channel system

PLZ-50F may be configured with up to five channels, and PLZ-30F may be configured with up to three channels. Isolated from each other, the channels can operate both independently and in synchronization. Different models of load units (PLZ150U and PLZ70UA) can be housed in a single frame.

Parallel operation for increased capacity

Up to five load modules may be operated in parallel, provided that adjacent load modules are of the same model. For example, when five load modules are parallel connected in a PLZ-50F frame, the system can function as a 375-watt load if the paralleled load modules are PLZ70UAs or as a 750-watt load if the paralleled load modules are PLZ150Us.

Others

- A setup memory function is provided to save the panel settings.
- The ABC preset memory function lets you preset the three most frequently used values.
- The system comes standard with GPIB and RS-232C communication ports.
- The analog-like rotary knobs and intuitive design make the system very easy to operate.
- The system has load input terminals and remote sensing terminals on its front and rear panels.
- The use of heat-sensitive, variable-speed fans and the pursuit of a more efficient cooling structure have resulted in high reliability and low noise.
- Six protection functions are provided, including over current protection (OCP), under voltage protection (UVP) and reverse connection protection (RVP).

Sequence function to enable load simulations

In constant current or constant resistance mode, sequence programs, each consisting of up to 255 steps, can be created with a minimum step execution time of 1 ms. A separate program can be run independently at the same time on a channel-by-channel basis.

External control functions

You can activate the input of an external reference voltage and turn on or off the load for each channel individually. Through the frame control terminals, you can perform channel-synchronized ABC preset memory call, setup memory call, and load on/off operations.

Frame control

You can connect two or more frames and use one of them to control the others (up to five frames can be connected at a time). This enables you to turn on or off the load and call preset values.

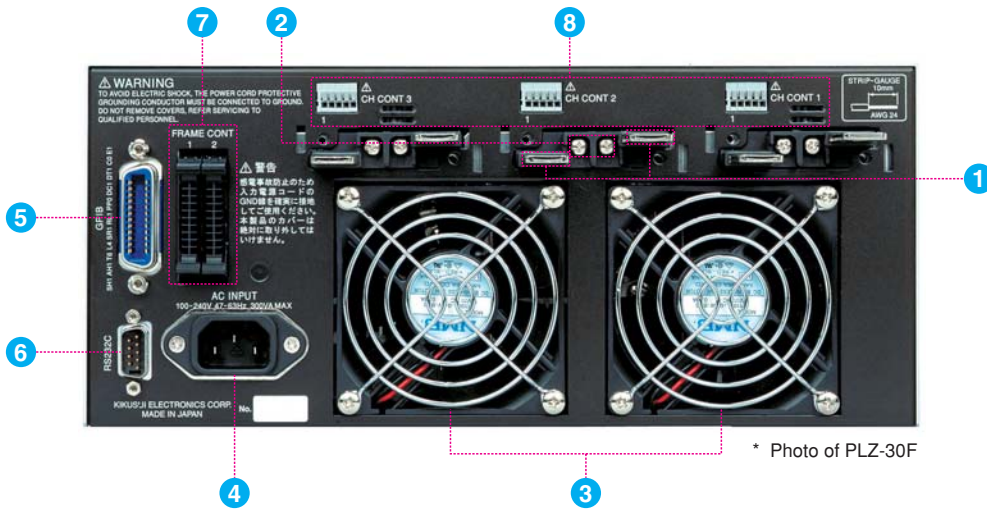

Rear panel

1 Rear-panel load input terminals

These terminals are used to connect this system with the device to be tested. They are connected to the load input terminals on the front panel in parallel inside the system.

2 Rear-panel remote sensing terminals

Sensing lines are connected to these terminals when compensating for voltage drops due to load wire resistance. Identical sets of remote sensing terminals are provided on the front and rear panels, and are connected in parallel inside the system.

3 Air vents

Cooling fans expel air through these vents to keep the temperature inside the system constant. The rotation speed of the cooling fans are controlled according to the internal temperature.

4 AC INPUT

5 GPIB

6 RS-232C

7 FRAME CONT

This connector is used to perform load on/off, memory call and other operations from the outside.

8 CH CONT

This connector is used to perform load on/off and external voltage reference control from the outside. It is also equipped with the terminals for current monitor output and power supply output for control.

Performance and Functions

High Basic Performance

Five operation modes

The system is capable of operating in five modes - constant current, constant resistance, constant voltage, constant current + constant voltage and constant resistance + constant voltage.

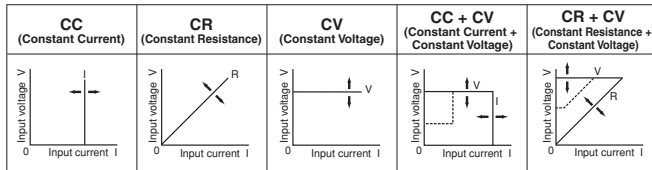

Variable slew rate

The slew rate determines the slope of change in the current when the set current needs to change sharply as in a transient response test. This system lets you set the current change rate per unit time as appropriate for the selected current range.

Slew rate

		PLZ150U	PLZ70UA
CC mode	H	0.10 to 2.40 A/μs	0.05 to 1.20 A/μs
	M	0.10 to 0.24 A/μs	0.05 to 0.12 A/μs
	L	24 mA/μs*	12 mA/μs*
CR mode	H	0.10 to 0.24 A/μs	0.05 to 0.12 A/μs
	M	24 mA/μs*	12 mA/μs*
	L	2.4 mA/μs*	1.2 mA/μs*
Resolution		0.01 A/μs	

* Fixed value

High precision and high resolution

The built-in three-range configuration provides both wide dynamic range and high precision. The voltmeter, ammeter and wattmeter functions that display values using up to five digits each and a minimum setting resolution of either 10 μA (PLZ70UA) or 20 μA (PLZ150U) are implemented.

Measurement display resolution

		Resolution
Voltmeter	15.75 to 150 V	0.01 V
	0 to 15.75 V	0.001 V
Ammeter	H	0.001 A
	M	0.0001 A
	L	0.01 mA
Wattmeter	Less than 100 W	0.01 W
	100 W or more	0.1 W

0-V input

The PLZ70UA model operates even when the input operating voltage is 0 V. This feature is indispensable for testing single-cell fuel cells. The continuing trend toward lower power consumption and semiconductor process miniaturization is driving semiconductor devices to operate with increasingly lower voltages. This makes PLZ70UA suitable for use when evaluating such power supplies.

Functions Available Only in Multi-Channel Systems

Diverse load on/off operations

Both load units and frames have LOAD keys on them. The load on/off operations listed below are available. You can choose any of these operations as suitable for your operating environment.

Load on/off operations

Selected channel only	Operation using the LOAD key of the load unit
All channels simultaneously	Operation using the LOAD key of the frame
Load on delay	Turns on the load when the set time elapses after the LOAD key is pressed.
Power on load	Turns on the load automatically when the system is powered on.
Auto load off timer	Turns off the load when the set time elapses after the load-on operation.
External control	Controls the load on/off operations using external signals.
Elapsed time display	Displays the time that elapses from the moment the load is turned on until it is turned off.
Load off voltage display	Stores the value of voltage recorded when the load is turned off.

Channel-synchronized operations

You can have all the channels operated in synchronization for the load on/off, ABC preset memory, setup memory and sequence operations, respectively.

Channel-synchronized operations

Load on/off	Turns on or off the load for all the channels simultaneously.
ABC preset memory	Calls memory data for all the channels simultaneously.
Setup memory	Saves or calls memory data for all the channels simultaneously.
Sequence	Executes or stops sequence programs for all the channels simultaneously.

Frame control

By connecting two or more frames, you can perform channel-synchronized load on/off, ABC preset memory call and setup memory call operations for all the channels simultaneously while controlling up to four frames from a single frame.

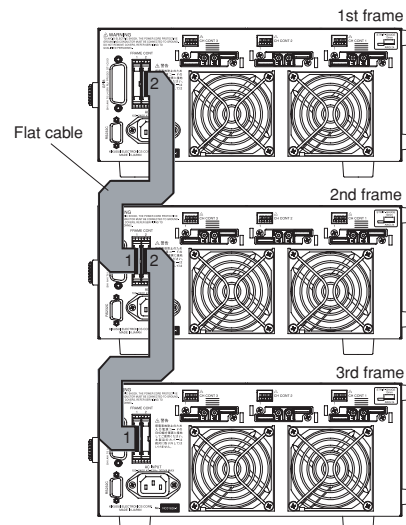

Support for Advanced Tests

Parallel operation

Adjacent load modules of the same model installed in the same frame can be operated in parallel*. Parallel operated load modules are regarded as a single channel, and their total current and resistance (conductance) values are used as displayed and set values. Parallel operated load modules and standalone load modules can coexist in the same frame.

* PLZ-50F can accommodate up to five load modules.

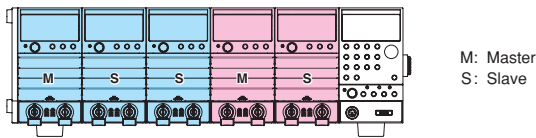

When PLZ-50F houses one set of three parallel operated load modules and another set of two parallel operated load modules

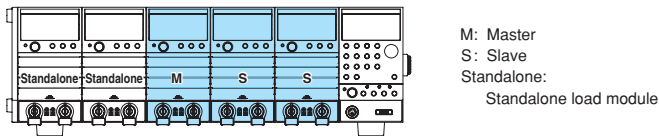

When PLZ-50F houses one set of three parallel operated load modules and two standalone load modules

Number of parallel operated load modules and capacities

Number of parallel operated load modules	PLZ70UA	PLZ150U
2	30 A/150 W	60 A/300 W
3	45 A/225 W	90 A/450 W
4	60 A/300 W	120 A/600 W
5	75 A/375 W	150 A/750 W

Sequence function

The sequence function automatically executes a stored program step by step in constant current or constant resistance mode. You can set a value and an execution time for each step individually, which enables you to perform simulations with various waveforms. A separate program can be prepared for each channel, and the backup function retains these programs even if the system is powered off.

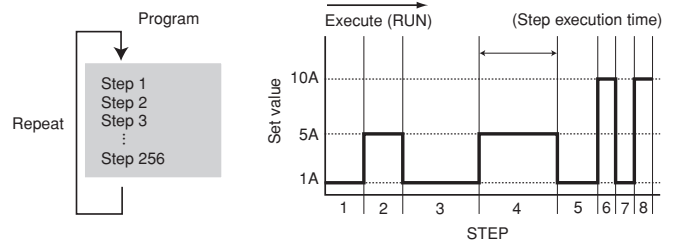

Sequence setting parameters

Mode	CC or CR
Step execution time	1 ms to 9999 s (0 = End of the step)
Maximum number of steps	255
Number of repetitions	0 to 9999 (9999 = Repeated infinitely)

Elapsed time display and auto load off timer

Combining four functions - elapsed time display, under voltage protection (UVP), load off voltage display and auto load off timer - makes it possible to perform two types of measurements that are useful in battery discharge tests - measurement of the time elapsed from the start of discharge until the final voltage is detected and measurement of the closed circuit voltage after the specified time elapses from the start of discharge.

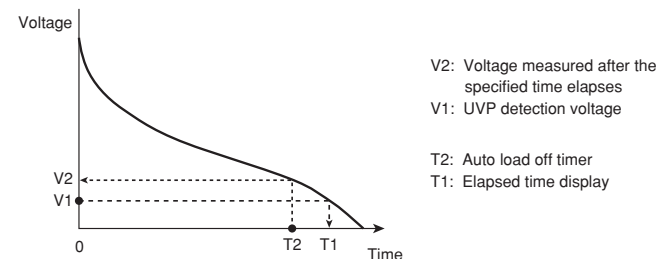

Switching function

Switching operations can be performed in constant current and constant resistance modes. The switching setting parameters are the switching level, switching frequency, duty factor and slew rate. These parameters can be changed while this mode is in operation.

Switching setting parameters

Duty factor	2% to 98%, in steps of 0.1%	
Frequency range	1 Hz to 20 kHz	
Frequency setting resolution	1 Hz to not higher than 1 kHz	1 Hz
	1 kHz to not higher than 10 kHz	10 Hz
	10 to 20 kHz	100 Hz

Performance and Functions

Soft start function

The soft start function allows the rise time of the current to be changed after the load-on operation in constant current mode. Since the rise time for the system can be changed according to the output-voltage rise time for the device being tested, you can conduct tests under highly realistic load conditions. (The soft start time can be selected from the following options - 0.1, 1, 3, 5, 10, 30, 100 and 300 ms.)

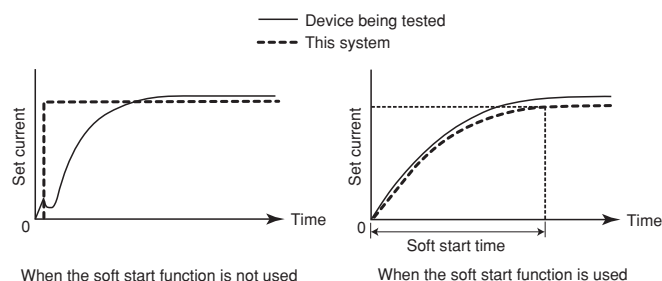

Remote sensing function

The remote sensing function compensates for voltage drops in load lines. It is used to set resistance and voltage values correctly and to make accurate voltage and power measurements. Particularly, the function improves the transitional characteristics in constant voltage and constant resistance modes, leading to stable operation.

ABC preset memories

Three memories A, B and C are provided for each range in constant current, constant resistance and constant voltage modes, and the set values can be saved. The stored set values can be called freely even while the load is on and saved again. In the constant current + constant voltage and constant resistance + constant voltage modes, the constant current and constant voltage memories and the constant resistance and constant voltage memories can be called and saved, respectively.

Setup memories

Up to four of the set values listed below can be saved in the setup memories. The set values are called or saved for all the channels simultaneously.

- Operation mode (CC, CR and CV/+CV)
- Current, resistance and voltage values recorded when saved
- Range setting
- Slew rate
- Switching frequency, duty factor and level
- Soft start
- Configuration settings
- ABC preset memory data
- Auto load off timer
- Sequence

Configuration setting

This function configures the settings related to the system operation, communication environment, etc. These settings are stored in the system memory and called when the power is turned on.

- Number of parallel operated load modules
- Operation mode in which the external reference voltage input is used
- Over current protection (OCP) load off function
- Over power protection (OPP) load off function
- Load on delay time
- Load on/off operation at the end of the sequence
- Polarity of load on external control (low/high)
- Load on/off operation at powering on
- Choice between GPIB and RS-232C
- GPIB address setting
- RS-232C communication speed

Ease of operation

All the knobs and keys necessary for the setting operations are provided on the frame panel. You can perform the setting operations by one hand while viewing the measured voltage and current values displayed on a channel-by-channel basis. The analog-like rotary knobs, which employ rotation speed-sensitive encoders, and intuitive design make the system very easy to operate.

Key lock function

This function locks the panel keys so that the set values, memory data, sequences and other settings cannot be changed.

Numerous protection functions

The system features the following protection functions - over current protection (OCP), over power protection (OPP), overvoltage protection (OVP), under voltage protection (UVP), over heat protection (OHP) and reverse connection protection (RVP). Because the OCP, OPP and UVP values can be changed on a per-channel basis, you can optimize the protection settings for each device to be tested.

Meeting System Application Needs

External controls

External controls are provided using the frame connector (FRAME CONT) and each channel connector (CH CONT). The frame connector (FRAME CONT) lets you perform the channel-synchronized load on/off, ABC preset memory call, setup memory call, load status output and alarm status output operations. Also, using the channel connector (CH CONT), you can perform the external voltage reference control, load on/off and input current monitor output operations.



Pin assignment of connector 1 (valid when ENABLE is at the low level)

No.	Signal name	Input/output	Function
1	A		Calls preset memory A.
2	B		Calls preset memory B.
3	C		Calls preset memory C.
4	AUX		Reserved
5	MEM0		Call setup memory 0.
6	MEM1	Input*1	Call setup memory 1.
7	MEM2		Call setup memory 2.
8	MEM3		Call setup memory 3.
9	ENABLE		Enables load on/off, calling of preset memories A, B and C, and calling of setup memories 0 to 3.*2
10	LOAD ON		Turns on the load.
11	N.C.		
12	N.C.	N.C.	
13	N.C.		
14	N.C.		
15	LOAD STATUS		Set to on when the load is on.
16	ALARM STATUS	Output*3	Set to on when an alarm is present.
17	+5VIF		5-V maximum output current 100 mA
18	N.C.	N.C.	N.C.
19	GND	GND	GND (chassis potential)
20	GND		

*1 Input: Becomes active when set to the low level and is pulled up to 5 V at 10 kΩ (low-level input voltage = 0 to 1 V; high-level input voltage = 4 to 5 V). The signal becomes valid when ENABLE is set to the low level. When two or more signals are set to the low level for ABC preset memory call and setup memory call, the last one that is set to low is regarded as valid.

*2 When ENABLE is on, these operations from the panel are disabled.

*3 Output: Open collector output, output withstand voltage 30 VDC, output saturation voltage about 1.1 V, maximum output current 100 mA

Pin assignment of CH CONT connector 1

No.	Signal name	Function
1	COM	Load input pin [-] (minus) pin potential
2	I MON	Load input current monitor output; 0 to 10 V, 0% to 100% of the rated current
3	EXT REF	External voltage reference input; 0 to 10 V, 0% to 100% of f.s
4	LOAD ON/OFF CONT	Load on input. Whether to make this signal active at the low or high level is determined by the polarity of load on/off external control, which is among the configuration settings. Pulled up to 5 V at 10 kΩ. Low-level input voltage = 0 to 1 V; high-level input voltage = 4 to 5 V.
5	+12V	12-V internal power supply output. The maximum output current is 50 mA.

Support for GPIB and RS-232C

The system comes standard with GPIB and RS-232C interfaces. It also complies with the following standards:



- IEEE Std 488.2-1992 IEEE Standard Codes, Formats, Protocols, and Common Commands For Use With IEEE Std 488.1-1987
- IEEE Std 488.1-1987 IEEE Standard Digital Interface for Programmable Instrumentation
- TIA/EIA-232F
- Standard Commands for Programmable Instruments (SCPI) version 1999.0

Specifications

Rating

		Model	PLZ150U	PLZ70UA
Operating voltage (DC)			1.5 V to 150 V	0 V to 150 V
Current/power	Range	H	30 A/150 W	15 A/75 W
		M	3 A/150 W	1.5 A/75 W
		L	300 mA/45 W	150 mA/22.5 W
Isolation voltage of the load input terminal			500 VDC	
Withstand voltage between load input terminal channels			500 VDC	
Minimum start voltage*1			0.3 V or greater	

*1 Minimum voltage at which the current starts flowing to the PLZ-U.

(The PLZ-U detects no signal at an input voltage less than or equal to approximately 0.3 V and an input current less than or equal to approximately 1 % of the range rating. Therefore, if the input voltage is gradually increased from 0 V, no current will flow until 0.3 V is exceeded. If a current greater than or equal to 1% of the range rating starts flowing, the current can flow at voltages less than equal to 0.3 V.)

CC mode

		Model	PLZ150U	PLZ70UA
Operating range	Range	H	0 A to 30 A	0 A to 15 A
		M	0 A to 3 A	0 A to 1.5 A
		L	0 A to 300 mA	0 A to 150 mA
Selectable range			0 % to 105 % of f.s	
Resolution	Range	H	2 mA	1 mA
		M	0.2 mA	0.1 mA
		L	0.02 mA	0.01 mA
Accuracy of setting	Range	H, M, and L	$\pm(0.2 \% \text{ of set} + 0.2 \% \text{ of f.s}) + V_{in}^*/500 \text{ k}\Omega$	
Input voltage variation*2	Range	H	2 mA	
		M	1 mA	
		L	0.1 mA	
Ripple	rms*3		3 mA	7.5 mA
		p-p*4	30 mA	50 mA

*1 V_{in} : Load input terminal voltage

*2 At a current greater than or equal to ($V_{in}/500 \text{ k}\Omega$)

*3 Measurement frequency bandwidth: 10 Hz to 1 MHz

*4 Measurement frequency bandwidth: 10 Hz to 20 MHz

CR mode

		Model	PLZ150U	PLZ70UA
Operating range The value inside parentheses is the conductance. *1	Range	H	PLZ150U OPEN to 50 m Ω (0 S to 20 S)	OPEN to 100 m Ω (0 S to 10 S)
		M	OPEN to 500 m Ω (0 S to 2 S)	OPEN to 1 Ω (0 S to 1 S)
		L	OPEN to 5 Ω (0 S to 200 mS)	OPEN to 10 Ω (0 S to 100 mS)
Selectable range			0 % to 105 % of f.s *2	
Resolution The value inside parentheses is the operating range.	Range	H	0.2 mS (0 S to 2 S)	0.1 mS (0 S to 1 S)
			2 mS (2 S to 20 S)	1 mS (1 S to 10 S)
		M	20 μ S (0 S to 200 mS)	10 μ S (0 S to 100 mS)
			0.2 mS (200 mS to 2 S)	0.1 mS (100 mS to 1 S)
		L	2 μ S (0 S to 20 mS)	1 μ S (0 S to 10 mS)
			20 μ S (20 mS to 200 mS)	10 μ S (10 mS to 100 mS)
Accuracy of setting*3	Range	H, M, and L	$\pm(0.5 \% \text{ of set}^4 + 0.5 \% \text{ of f.s}^5) + V_{in}/500 \text{ k}\Omega$	

*1 Conductance [S] = (Input current [A]/input voltage [V]) = (1/resistance [Ω])

*2 Conductance f.s

*3 Converted value in terms of the input current, during remote sensing

*4 set = input voltage \times specified conductance = (input voltage/specified resistance)

*5 f.s = Rated current of the specified range

CV mode

		Model	PLZ150U	PLZ70UA
Operating range	Range	H	1.5 V to 150 V	0 V to 150 V
		L	1.5 V to 15 V	0 V to 15 V
Selectable range			0 % to 105 % of f.s	
Resolution	Range	H	10 mV	
		L	1 mV	
Accuracy of setting	Range	H and L	$\pm(0.1 \% \text{ of set} + 0.1 \% \text{ of f.s})$	
Input current variation*1			12 mV	

*1 During remote sensing

Voltmeter

		Model	PLZ150U	PLZ70UA
Measurement range			0 V to 150.0 V	
Resolution	15.75 V to 150 V		0.01 V	
	0 V to 15.75 V		0.001 V	
Measurement accuracy			±(0.1 % of rdg + 15 digits)	

Ammeter

		Model	PLZ150U	PLZ70UA
Measurement range	Range	H	0 A to 30 A	0 A to 15 A
		M	0 A to 3 A	0 A to 1.5 A
		L	0 mA to 300 mA	0 mA to 150 mA
Resolution	Range	H	0.001 A	
		M	0.0001 A	
		L	0.01 mA	
Measurement accuracy			±(0.2 % of rdg + 0.3 % of f.s)	

Wattmeter*1

		Model	PLZ150U	PLZ70UA
Measurement range			0 W to 150 W	0 W to 75 W
Resolution	100 W minimum		0.01 W	
	100 W or greater		0.1 W	

*1 Product of the measured voltage and measured current

Switching mode

		Model	PLZ150U	PLZ70UA
Operation mode			CC and CR	
Selectable frequency range			1 Hz to 20 kHz	
Duty cycle setting			2 % to 98 %, 0.1 % steps	
Frequency resolution	1 Hz to less than 1 kHz		1 Hz	
	1 kHz to less than 10 kHz		10 Hz	
	10 kHz to 20 kHz		100 Hz	
Accuracy of frequency setting			±(0.5 % of set)	

Slew rate

		Model	PLZ150U	PLZ70UA
Operation mode			CC and CR	
Selectable range (CC)	Range	H	0.10 A/μs to 2.40 A/μs	0.05 A/μ to 1.20 A/μs
		M	0.10 A/μs to 0.24 A/μs	0.05 A/μ to 0.12 A/μs
		L	24 mA/μs*1	12 mA/μs*1
Selectable range (CR)	Range	H	0.10 A/μs to 0.24 A/μs	0.05 A/μ to 0.12 A/μs
		M	24 mA/μs*1	12 mA/μs*1
		L	2.4 mA/μs*1	1.2 mA/μs*1
Resolution			0.01 A/μs	
Accuracy of setting*2			±(10 % of set + 5 μs)	

*1 Fixed value

*2 Time to reach from 10 % to 90 % when the current is changed from 2 % to 100 % of the rated current of H range.

Soft start

		Model	PLZ150U	PLZ70UA
Operation mode			CC	
Selectable time range			0.1, 1, 3, 10, 30, 100, or 300 ms	
Time accuracy			±(30 % of set + 100 μs)	

Sequence function

		Model	PLZ150U	PLZ70UA
Sequence	Operation mode		CC and CR	
	Maximum number of steps		255	
	Step execution time		1 ms to 9 999 s	
	Number of loops		1 to 9999 (9999 is infinite loop)	

Specifications

Protection function

	Model	PLZ150U	PLZ70UA
Overvoltage protection (OVP)		Turns off the load at 110 % of the rated voltage	
Overcurrent protection (OCP)		Set the value in the range of 0 % to 110 % of the rated current of H range. Trips at the value or 110% of the rated current of the range, whichever is less. The action taken when the OCP trips can be set to load off or limit.	
Overpower protection (OPP)		Set the value in the range of 0 % to 110 % of the rated power of H range. Trips at the value or 110% of the rated power of the range, whichever is less. The action taken when the OPP trips can be set to load off or limit.	
Overheat protection (OHP)		Trips when the heat sink temperature reaches 95 °C. The action taken when the OHP trips is to turn the load off.	
Reverse connection protection (RVP)		Short-term protection provided by a short-circuit system using a protection diode. The action taken when the OHP trips is to turn the load off.	
Undervoltage protection (UVP)		Set the value to off or in the range of 0 % to 100 % of the rated voltage. The action taken when the OHP trips is to turn the load off.	

Communication function

	Model	PLZ150U	PLZ70UA
GPIB		IEEE std. 488.2-1994 SH1, AH1, T6, L4, SR1, RL1, PP0, DC1, DT1, C0, and E1	
		Supports the SCPI command set Sets panel functions except the POWER switch and key lock and reads measured values	
RS-232C		D-SUB 9-pin connector (conforms to EIA-232-D)	
		Sets panel functions except the POWER switch and key lock and reads measured values Baud rate: 2400, 4800, 9600, or 19200 bps; stop bit: 1; data length: 8 bits; parity: NONE; and flow control: XON/OFF.	

Inter-frame control and external control

	Model	PLZ150U	PLZ70UA
Inter-frame control		Controls up to four slave frames from the master frame.	
		Enables you to turn on/off the load, recall presets ABC on all channels simultaneously, and recall setup memories 0 to 3.	
External control	Recall input of preset memories A, B, and C	Recalls preset memories A, B, and C on all channels simultaneously	
	Setup memory recall input	Recalls the setup memory 0 to 3	
	Enable input	Enables the turning on/off of the load, recalling of presets ABC on all channels simultaneously, and recalling of setup memories 0 to 3.	
	Load-on input	Turns on the load on all channels simultaneously.	
	Load on status output	On when the load is on (open collector output)	
	Alarm status output	On when the alarm is on (open collector output)	
	Internal power output	5 V and maximum output current of 100 mA	
Input signal		Low active, pull up to 5 V using 10 k Ω . Low level input voltage: 0 V to 1 V, high level input voltage: 4 V to 5 V	
Output signal		Open collector, output withstand voltage of 30 VDC, output saturation voltage of approximately 1.1 V, and maximum output current of 100 mA.	

Remote sensing

	Model	PLZ150U	PLZ70UA
Sensing voltage that can be compensated		2 V for a single line	

Miscellaneous

	Model	PLZ150U	PLZ70UA
ABC preset memories		Saves settings (A, B, and C) for each operation mode of each range	
Setup memories		Saves four sets of setup parameters	
Elapsed time display		Measures the time from when the load is turned on to when the load is turned off (0.1 s to 99999 s)	
Auto load off timer		Turns off the load after the specified time elapses (off or 1 s to 99999 s)	
Delayed load-on		Turns on the load after the specified time elapses (0 ms to 1 s, 10 ms steps)	
Parallel operation		Possible between adjacent load units (same model) in the frame.	

External analog control

	Model	PLZ150U	PLZ70UA
Power output		12 V and maximum output current of 50 mA.	
External voltage control input*1		Operates in CC, CR, and CV modes. 0 % to 100 % of f.s in the range of 0 V to 10 V.	
Load-on input.		Low active (or high active), pull up to 5 V using 10 k Ω . Low level input voltage: 0 V to 1 V, high level input voltage: 4 V to 5 V	
Current monitor output		0 % to 100 % of the rated current in the range of 0 V to 10 V	
Common		Negative pin electric potential of the load input terminal	

*1 The time for updating the setting in CR or CV mode is approximately 100 ms.

General Specifications

	Model	PLZ150U	PLZ70UA
Weight		Approx. 2 kg	
Accessories	Rear load input terminal cover	1 pc.	
	Set of screws for the load input connector	2 sets (M6 bolt, M6 nut, M6 spring washer, M4 screw)	
	Load unit attachment screws	2 pcs. (M3-10 screws, attached to the unit)	
	Sensing terminal screw on the rear panel	2 pcs. (M3-6 screws, attached to the unit)	

	Model	PLZ30F	PLZ50F
Rated supply voltage		100 VAC to 240 VAC (90 VAC to 250 V) single phase	
Rated frequency		50 Hz or 60 Hz (47 Hz to 63 Hz)	
Power consumption	Frame alone	33 VA or less	40 VA or less
	When load units are installed in all channels	300 VAm _{ax}	500 VAm _{ax}
Cooling system		Forced air cooling using a heat sensing variable speed fan.	
Operating temperature range		0 °C to 40 °C	
Operating humidity range		20 % to 85 % RH (without condensation)	
Storage temperature range		-20 °C to 70 °C	
Storage humidity range		90 % RH or less (without condensation)	
Insulation resistance	Primary - chassis	500 VDC, 30 M Ω or more (ambient humidity of 70% RH or less)	
Withstand voltage	Primary - chassis	No abnormalities at 1500 VAC for 1 minute.	
Ground continuity		25 Aac, 0.1 Ω or less	
Battery backup		Backs up the setup data immediately before the power is turned off Battery life: 3 years or longer (at 25 °C)	
Number of installable load modules		3	5
Dimensions (mm)		See outline drawing.	
Weight	Frame alone	Approx. 5 kg	Approx. 7 kg
Accessories	Power cord	1 pc. (with SVT3, 18AWG, 3-prong plug, cable length of 2.4 m)	
	Blank panel (front panel)	2 pcs. maximum*1	4 pcs. maximum*1
	Protection dummy plug	2 pcs. (for the FRAME CONT connector, attached to the unit)	
	Operation manual	1 pc.	
Electromagnetic compatibility *1, *2		Conforms to the requirements of the following directives and standards EMC Directive 89/336/EEC EN61326:1997/A2:2001 Emission: Class A Immunity: Minimum immunity test requirement EN61000-3-2:2000 EN61000-3-3:1995/A1:2001	
Safety *2, *3		Conforms to the requirements of the following directives and standards Low Voltage Directive 73/23/EEC EN61010-1:2001 Class I Pollution degree 2	

*1 In products that have load units installed, blank panels are installed in the empty slots. In products that contain the frame alone, the maximum number of blank panels are installed.

*2 Only on models that have CE marking on the panel.

*3 Not applicable to custom order models.

*4 This unit is a Class 1 device. Be sure to ground the protective conductor terminal of the unit. The safety of the unit is not guaranteed unless the unit is grounded properly.

External Dimensions and Rack Mounting

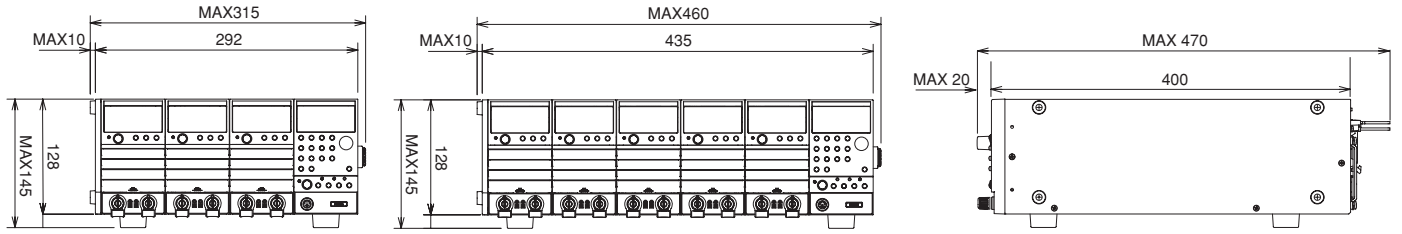

Unit: mm

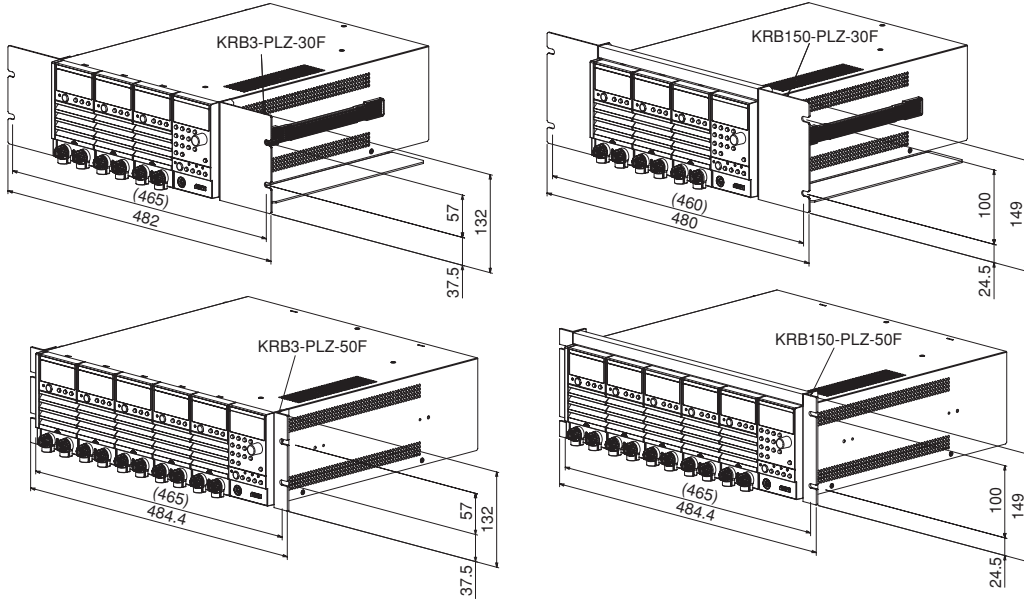

<p>PLZ70UA (0 V input type) H range</p>		<p>PLZ150U (1.5 V input type) H range</p>	
<p>PLZ70UA (0 V input type) M range</p>		<p>PLZ150U (1.5 V input type) M range</p>	
<p>PLZ70UA (0 V input type) L range</p>		<p>PLZ150U (1.5 V input type) L range</p>	

Ordering Code

PLZ-U Series Component

Product name	Model name	Remarks
Load Unit	PLZ70UA	75W/15A, 0V-150V
Load Unit	PLZ150U	150W/30A, 1.5V-150V
Frame (3 ch)	PLZ-30F	accommodating up to 3ea load modules
Frame (5 ch)	PLZ-50F	accommodating up to 5ea load modules

Ordering code * Please inquire by following code

Model name	Frame model	PLZ70UA	PLZ150U	Total number of unit
PLZ30F-70UA0-150U1	PLZ-30F	0	1	1
PLZ30F-70UA0-150U2		0	2	2
PLZ30F-70UA0-150U3		0	3	3
PLZ30F-70UA1-150U0		1	0	1
PLZ30F-70UA1-150U1		1	1	2
PLZ30F-70UA1-150U2		1	2	3
PLZ30F-70UA2-150U0		2	0	2
PLZ30F-70UA2-150U1		2	1	3
PLZ30F-70UA3-150U0		3	0	3
PLZ50F-70UA0-150U1		PLZ-50F	0	1
PLZ50F-70UA0-150U2	0		2	2
PLZ50F-70UA0-150U3	0		3	3
PLZ50F-70UA0-150U4	0		4	4
PLZ50F-70UA0-150U5	0		5	5
PLZ50F-70UA1-150U0	1		0	1
PLZ50F-70UA1-150U1	1		1	2
PLZ50F-70UA1-150U2	1		2	3
PLZ50F-70UA1-150U3	1		3	4
PLZ50F-70UA1-150U4	1		4	5
PLZ50F-70UA2-150U0	2		0	2
PLZ50F-70UA2-150U1	2		1	3
PLZ50F-70UA2-150U2	2		2	4
PLZ50F-70UA2-150U3	2		3	5
PLZ50F-70UA3-150U0	3		0	3
PLZ50F-70UA3-150U1	3		1	4
PLZ50F-70UA3-150U2	3		2	5
PLZ50F-70UA4-150U0	4		0	4
PLZ50F-70UA4-150U1	4		1	5
PLZ50F-70UA5-150U0	5		0	5

Options * for connection between frames

Control Flat Cabel
PC01-PLZ-4W (300mm)
PC02-PLZ-4W (550mm)



KIKUSUI ELECTRONICS CORPORATION

1-1-3, Higashiyamata, Tsuzuki-ku, Yokohama, 224-0023, Japan
Phone: (+81) 45-593-7570, Facsimile: (+81) 45-593-7571, www.kikusui.co.jp

KIKUSUI AMERICA, INC. Toll Free 1-800-KIKUSUI www.kikusui.us



1633 Bayshore Highway, Suite 331, Burlingame, CA 94010
Phone : 650-259-5900 Facsimile : 650-259-5904

KIKUSUI TRADING (SHANGHAI) Co., Ltd. www.kikusui.cn



Room, D-01, 11F, Majesty Bld, No.138, Pudong Ave, Shanghai City
Phone : 021-5887-9067 Facsimile : 021-5887-9069

For our local sales distributors and representatives, please refer to "sales network" of our website.

Printed in Japan

■Distributor:



TEST INSTRUMENTS & POWER SUPPLIES
TEL: 0118 9786911 Fax: 0118 9792338
www.telonic.co.uk info@telonic.co.uk
SALES : SERVICE : CALIBRATION : HIRE

■ All products contained in this catalogue are equipment and devices that are premised on use under the supervision of qualified personnel, and are not designed or produced for home-use or use by general consumers. ■ Specifications, design and so forth are subject to change without prior notice to improve the quality. ■ Product names and prices are subject to change and production may be discontinued when necessary. ■ Product names, company names and brand names contained in this catalogue represent the respective registered trade name or trade mark. ■ Colors, textures and so forth of photographs shown in this catalogue may differ from actual products due to a limited fidelity in printing. ■ Although every effort has been made to provide the information as accurate as possible for this catalogue, certain details have unavoidably been omitted due to limitations in space. ■ If you find any misprints or errors in this catalogue, it would be appreciated if you would inform us. ■ Please contact our distributors to confirm specifications, price, accessories or anything that may be unclear when placing an order or concluding a purchasing agreement.

Issue:June.2008 2008061KSOHEC41